

175 Series Electrical Actuator

1 INTRODUCTION

GAC's 175 Series Integrated Pump Mounted Actuators are field proven proportional actuators designed to mount directly to fuel injection Bosch "P" style or similar pumps to achieve an integrated proportional servo fuel package. The design is versatile with numerous options and mounting kits available in order to adapt to other fuel pumps. See below.

2 SELECTION CHART

Product	12 Volt	24 Volt	Mating Connector Included	Return Spring	Position Feedback Sensor	Installation Kit (Included)	Heavy Duty Bearing Retainer	Bearing Bore Protective Plug-1	Lever to Link Connection-2
ACD175A-12	▪					KT283		▪	2x Bearing
ACD175A-24		▪				KT283		▪	2x Bearing
ADD175A-12	▪					KT289			1x Bearing
ADD175A-24		▪				KT289			1x Bearing
ADD175HD-24		▪				KT289	▪	▪	1x Bearing
ADD175F-12	▪				▪	KT289			1x Bearing
ADD175F-24		▪			▪	KT289			1x Bearing
ADD175SA-24		▪		▪		KT270		▪	Direct Link
ADE175A-12	▪		▪			KT289			1x Bearing
ADE175A-24		▪	▪			KT289			1x Bearing
T732012023	▪					KT289		▪	2x Bearing

NOTE 1 To protect paint or other debris from entering main shaft bore.
 2 The standard connection is one bearing rolling on link piece provided in KT289. Two bearings are sometimes needed to accommodate rank height variances across different fuel pump models. Lever assembly on ADD-175SA-24 is designed to work with specially modified rack and linkage, consult GAC for details.
 3 OEM part number for Lovol brand engines.

Others: Select models have GAC logo embossed on top cover. On some models, lock washers are used in place of flat washers to tighten down the covers. Contact GAC if special accommodation is needed.

Item	Model Number
Actuator Mating Connector	EC1300
ADD Packard Actuators - Connector Kit Replacement / (2 Terminal)	EC1310
Actuator Mating Cable Harness (6 ft.) [1.8m]	CH1215
ADD175F-12/24 Position Feedback Sensor Mating Connector	EC1523
ADD175F-12/24 Position Feedback Sensor Harness, 6 Ft. (1.8m)	CH1243

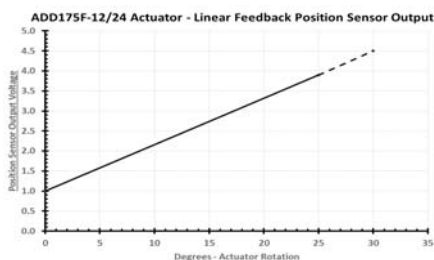

ADD175F-12/24 Position Feedback Sensor Mating Connector EC1523



PIN	SIGNAL	CH1243 Harness	SN120 Sensor
A	+5V	RED	GREEN
B	GND	BLACK	BROWN
C	OUT	WHITE	WHITE

Installation Kits	Description
KT153	175 Series Installation Kit - Motorpal Pump PP#M10P1i
KT197	175 Series Installation Kit - Bosch EDC Governor Housing - Mounting Plate, Linkage, Gasket and Installation Hardware
KT175-RS-R	175 Series Installation Kit For Bosch RS/RSV Governor / Right Hand Rack / Mounts Actuator Directly to Intermediary Mechanical Governor Housing - Adapter Plate, Linkage, Gasket and Installation Hardware
KT175-RS-R-Zexel	175 Series Installation Kit - For Zexel RS/RSV Governor / Right Hand Rack / Mounts Actuator Directly to Intermediary Mechanical Governor Housing - Adapter Plate, Linkage, Gaskets (Governor Housing and Actuator) and Installation Hardware
KT175A-R	175 Series Installation Kit - For Bosch 'A' size Pump with a Right Hand Rack / Mounts Actuator Directly onto an Adapter Plate. Includes Adapter Plate, Linkage, Gaskets, Bearing Retainer, Shims and Installation Hardware
KT175A-R-SA	175 Series Installation Kit - For Bosch 'A' size Pump with a Right Hand Rack / Mounts Actuator Directly onto an Adapter Plate. Includes Adapter Plate, Linkage, Gaskets, Bearing Retainer, Shims and Installation Hardware. For Mounting ADD175SA-24 Actuator with Internal Return Spring
KT275	175 or 275 Installation Kit - Bosch P 3000 Series Camshaft Bearing Retainer Kit - Plate, Gasket, Seal, Shims and Installation Hardware
KT276	175 or 275 Installation Kit - Bosch P 7000 Series Camshaft Bearing Retainer Kit - Plate, Gasket, Seal, Shims and Installation Hardware
KT283	ACD175A Installation Kit - Spare for BYC Asimco Pumps (Included with Actuator) - Hardware, Gasket, Shutoff Plate, Spring
KT289	ADD/ADE175 Series Installation Kit - Spare for Bosch-Style Pumps (Included with Actuator) - Hardware, Gasket, Shutoff Plate, Spring, Retainer, Linkage / Note - KT289 includes all of KT283 (BYC ASIMCO installation kit) plus Retainer and Linkage

3 SPECIFICATIONS

PERFORMANCE	
Net Force	6.2 lb-ft (27.5 N)
Max Operating Stroke	0.80 in (21 mm)
Response Time (10-90%, 2-19 mm)	35 msec
ELECTRICAL POWER INPUT	
Operating Voltage	12 VDC or 24 VDC
Nominal Operating Current	4.0 A (12 VDC) 2.0 A (24 VDC)
Max. Continuous Current	5.8 A (12 VDC) 3.1 A (24 VDC)
Nominal Coil Resistance	7.2Ω (12V) 2.0Ω (24V)
ENVIRONMENTAL	
Operating Temperature	-40 to 257°F (-40 to 125°C)
Relative Humidity	Up to 100%
Vibration	Heavy Duty HD version: Random vibration: 31grms vertical, 17grms transversal, 12grms longitudinal @ 20-2000Hz
	All other variants: 21g peak @ 100-2000Hz
Shock	20g @ 11 msec
All Surface Finishes	Fungus Proof and Corrosion Resistant
PHYSICAL	
Dimensions	See Section 4
Weight	4.75 lb (2.2 kg)

4 DIMENSIONS

Dimension Units	
[xx.x] -----	[mm]
xx.x -----	in

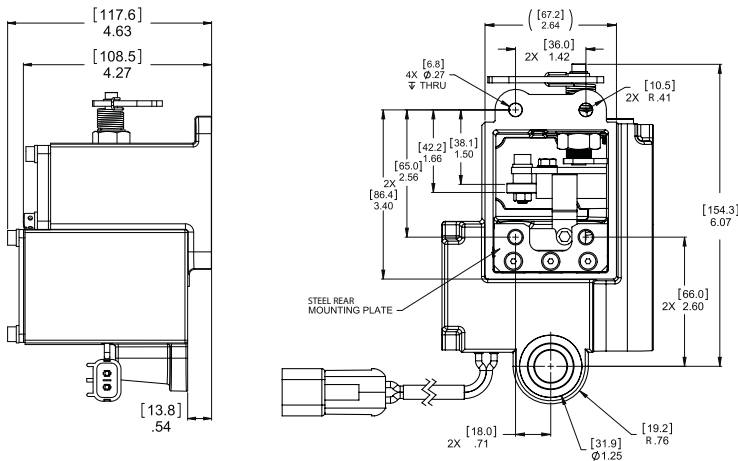

5 PREPARATION

If the fuel injection pump is equipped with a mechanical governor, it must be removed. GAC recommends that this modification be performed by a qualified fuel injection service facility. The following procedure lists the general steps required to remove the mechanical governor.

NOTE The mechanical governor will release oil during removal.

1. Remove the rear housing from the mechanical governor and disconnect the governor linkage from the pump fuel rack. Remove the flyweight assembly. A special tool is required.
2. Remove the intermediate governor housing. This leaves only the rack and camshaft protruding from the pump.
3. Install the appropriate adapter plate to provide the transition required from the actuator to the mounting holes formerly held by the governor housing. This plate must have countersunk holes for the mounting screws.

6 INSTALLING THE ACTUATOR

All hardware needed to attach the actuator to the pump is located in both kits KT283 and KT289, which are supplied with the actuator. The following installation instructions will refer to figures located on the next page.

1. Place the spring seat (1) over the fuel rack and slide it to the body of the fuel pump (see Figure 1-1). Slide the fuel rack return spring (2) over the fuel rack and against the spring seat.
2. Attach the rack connection link assembly (4, 5, 6, 7) to the fuel rack with two M5 X 10 mm long retaining screws (3) that include patches of Loctite adhesive. Torque the screws to 3-4 NM.
3. Remove the upper actuator cover (8) and o'ring seal (25).
4. Clean the actuator to pump adapter mounting surface so that it is free of any debris.
5. Insert two M6 X 16 mm long screws (15) and spring washers (16) through the lower mounting holes inside the upper actuator cavity (see Figure 1-3).
6. Align the gasket (29) as shown in (Figure 1-4) and install it over the two screws and carefully slip the actuator over the fuel rack assembly until the two lower screws just start to meet the fuel pump mounting holes.

IMPORTANT Alternate the turning of following mounting screws so that the actuator is aligned properly with the pump adapter plate.

7. Insert a ball end hex wrench through the access point located on the operating lever (17) and tighten the left lower mounting screw (15) a few turns.
8. Pull the operating lever outward and slide the ball end hex wrench into the space between the operating lever and the access point in the housing of the actuator and tighten the right lower mounting screw.
9. Once these two screws are fully engaged (do not tighten at this time) into the pump housing, insert two additional M6 X 16 mm long screws (15) and spring washers (16) into the top two mounting holes of the actuator and thread into the pump housing.
10. Torque all four mounting screws to 5-6 NM.
11. Verify that the fuel rack assembly moves in and out freely inside the upper cavity of the actuator.
12. Carefully loosen screw (11) and (20) over the slotted portion of the adjustment plate so that the operating lever bearing assembly (21) can be moved away from the fuel rack connection link.
13. Ensure that the fuel rack is as far out of the pump as possible.
14. Rotate the operating lever (17) out from the actuator until it stops (the armature of the actuator will be in contact with the lower cover (9) and hold in this position.
15. Rotate the adjustment plate and lever bearing assembly (21) in towards the fuel rack so that contact between the bearing and rack connection link is made. Continue to push in an additional 1 to 2 mm. While holding this position torque the operating lever assembly shaft screw (11) and screw (20) to 4-6 NM.
16. Inspect the assembly to ensure all screws are tight and the fuel rack moves smoothly without any binding. Push in the fuel rack manually to the full fuel position and rotate the fuel shut off lever (22) to minimum fuel to confirm that the shut off lever contacts the metal plate (6) on the fuel rack connector assembly and forces the fuel rack to minimum position.
17. The operating lever has a maximum fuel adjustment set screw (23) which can be used to restrict the fuel rack travel.

NOTE When installed, the cover must not hit the internal operating lever or the maximum fuel adjustment screw. Torque the cover screws to 2-3 NM. Check for any oil leaks. Lock-wire the lower screws for tamper resistance.

CAUTION Setting high fuel levels may cause the maximum fuel adjusting screw to hit the top cover, which can change the minimum fuel position. This could lead to a dangerous condition. When setting fuel levels above 17mm, insure that the adjusting screw does not contact the top cover at minimum level. Make sure that the cold start magnet is de-energized when adjusting the actuator with the cold start option.

With the fuel pump operating on the engine, the maximum fuel setting screw can be adjusted to provide specific horsepower. Once this setting is made torque the locknut (24) on the fuel adjustment screw to 5-6 NM.

Rotate the manual shut off lever (22) to the stop position and ensure that the fuel is completely shutoff and the engine stops. With the engine shut down, install the upper chamber cover (8) and o'ring seal (25) by first applying Loctite 222 to the six screws (26, 27) provided.

7 WIRING

The 175 Series Integral Electric Actuator is prewired for 12 or 24VDC operation. Use the included cable harness or make up a cable harness to connect the actuator to the speed control unit.

WARNING Do not use the 175 Series actuator on a 32-volt system. Contact the factory for assistance.

CAUTION The engine should be equipped with an independent shut down device to prevent overspeed, which can cause equipment damage or personal injury.

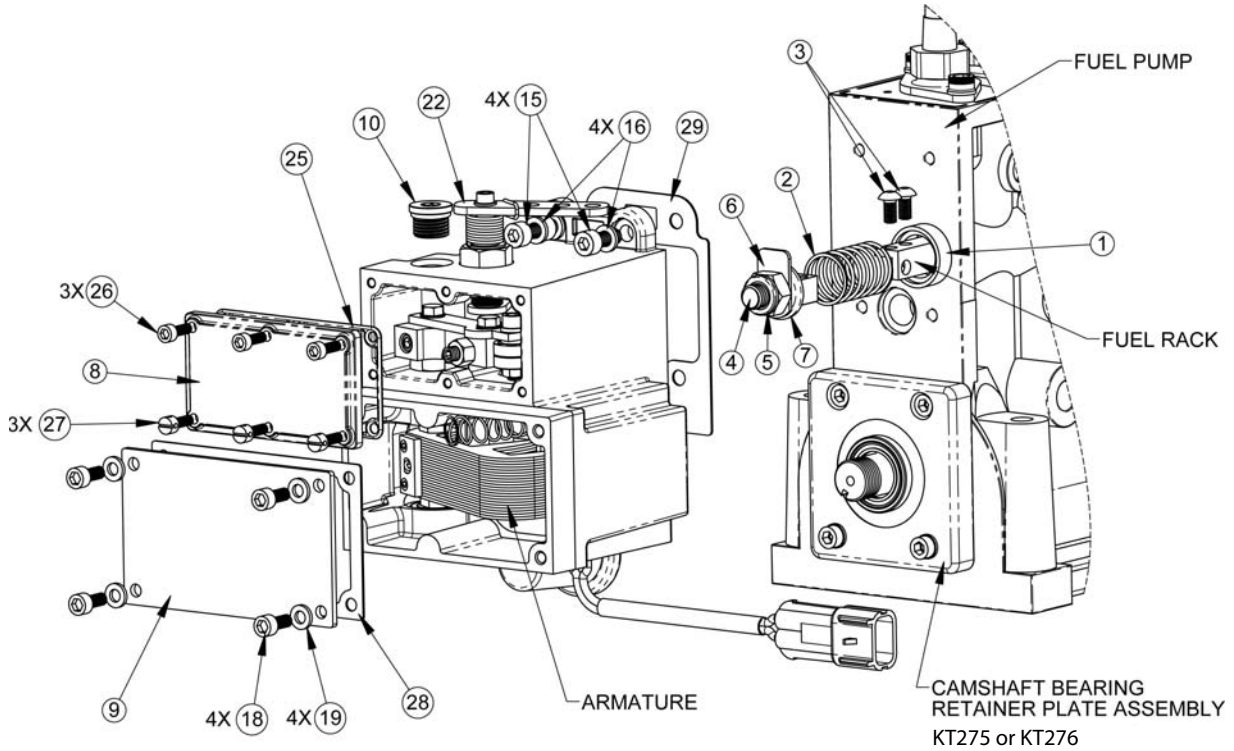

FIGURE 1-1

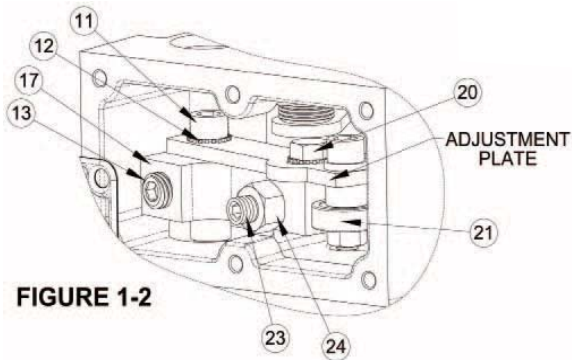

FIGURE 1-2

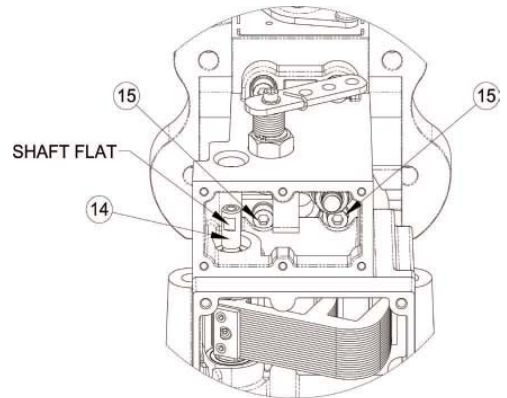

FIGURE 1-3

Mounting Kits KT289 & KT283

KT283 is specific to the BYC (Asimco) fuel injection pump where the retainer and link are already included with the fuel pump. KT289 comes with the retainer and link, giving the customer a choice of whether or not to use the two included components.

	KT283	KT289
Link		X
Retainer		X

APPLY PRESSURE SENSITIVE ADHESIVE SIDE OF GASKET TO ACTUATOR MOUNTING FACE.

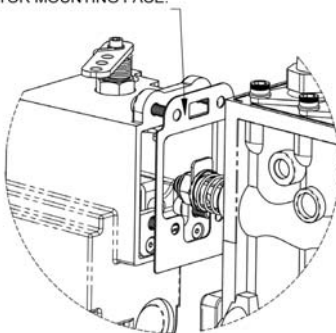

FIGURE 1-4

