

225 Series Electrical Actuator

1 SELECTION CHART

PRODUCT NO.	System Voltage		Multi Voltage	Connector			Sandcast Housing	High Temp Applications	Return Spring		Position Feedback Sensor
	12	24		MIL	Commercial	Packard			Lesser	Greater	
ACB225			▪	▪			▪				
ADB225			▪	▪							
ADB225F		▪		▪							▪
ADB225G			▪	▪					▪		
ADC225S-12	▪				▪						
ADC225S-24		▪			▪						
ADC225GS-12	▪				▪				▪		
ADC225GS-24		▪			▪				▪		
ADC225JS-12	▪				▪					▪	
ADC225JS-24		▪			▪					▪	
ADC225KS-12	▪				▪			▪			
ADC225KS-24		▪			▪			▪			
ADD225S-12	▪					▪					
ADD225S-24		▪				▪					
ADD225GSC-12	▪					▪			▪		
ADD225GSC-24		▪				▪			▪		

2 SPECIFICATIONS

PERFORMANCE	
Available Torque (w/o Return Spring)	2.2 ft-lb max (2.7 Nm)
Maximum Operating Shaft Travel	25° ±1° CW/CCW
POWER INPUT	
Operating Voltage	12 or 24 VDC
Normal Operating Current	3.0 Amps @ 12 VDC 1.5 Amps @ 24 VDC
Maximum Current Continuously Rated	8.0 Amps @ 12 VDC 4.0 Amps @ 24 VDC
ENVIRONMENT	
Operating Temperature Range	-65°F to +200°F (-54°C to +95°C)
Relative Humidity	up to 100%
All Surface Finishes	Fungus Proof and Corrosion Resistant
PHYSICAL	
Dimensions	See Next Section
Weight	8.25 lb (3.75 kg)
Mounting	Any Position, electrical connector at the top preferred
RELIABILITY	
Vibration Testing	Up to 20 G, 50 - 500 Hz 100% Tested

AVAILABLE CONNECTORS

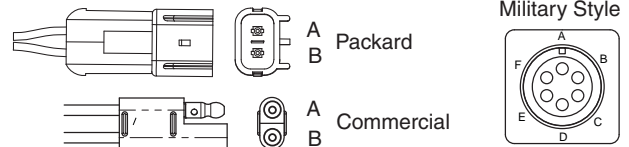

PRODUCT PREFIX	CONNECTOR PART NUMBER	CONNECTOR DESCRIPTION
ACB/ADB	EC1000	Military Style Mating Connector Kit / Straight / 6 Terminals
ACB/ADB	EC1010	Military Style Mating Connector Kit / 90° / 6 Terminals
ADD	EC1300	Packard - Mating Connector Kit
PRODUCT PREFIX	HARNES PART NUMBER	HARNES DESCRIPTION
ACB/ADB	CH1203	Military Style 12 ft. (3.6m) Harness with Straight EC1000 / 6 Terminal Connector
ACB/ADB	CH1210	Military Style 12 ft. (3.6m) Harness with 90° EC1010 Connector / 6 Terminals
ADC	CH1206	Commercial 2 Terminal Connector on 4 ft. (1.2m) Harness
ADC	CH251-2134	Commercial 2 Terminal Connector on 7 ft. (2.13m) Harness - <u>Included with Actuator</u>
ADD	CH1215	Packard 2 Terminal Connector EC1300 on 6 ft. (1.8m) Harness

3 DIMENSIONS FOR ADB/ADC & ADD VERSIONS

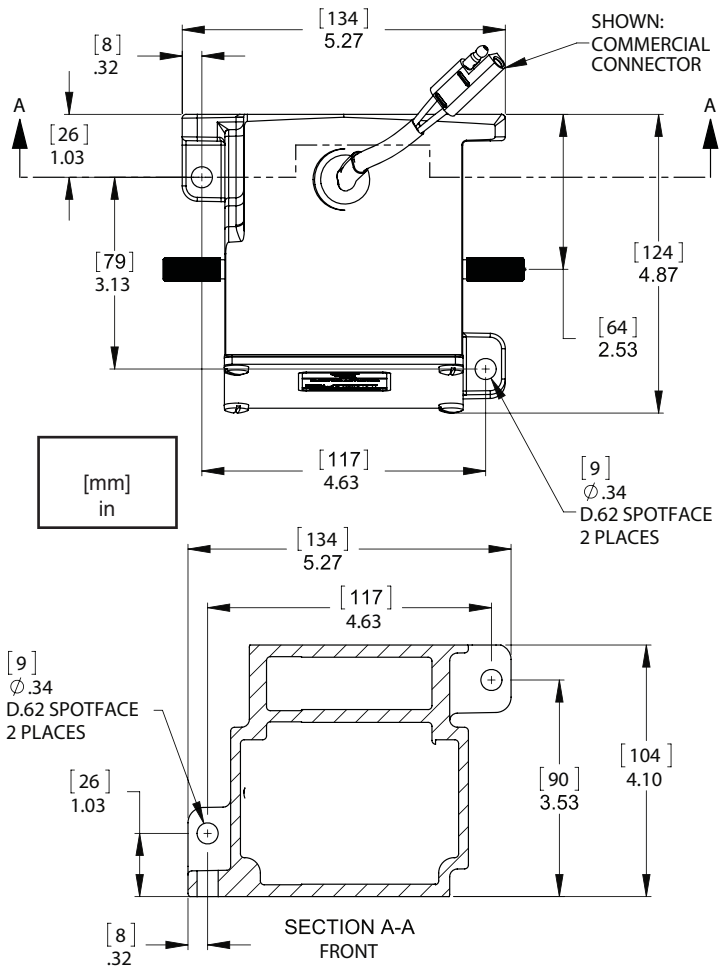

DIMENSIONS FOR ACB VERSION

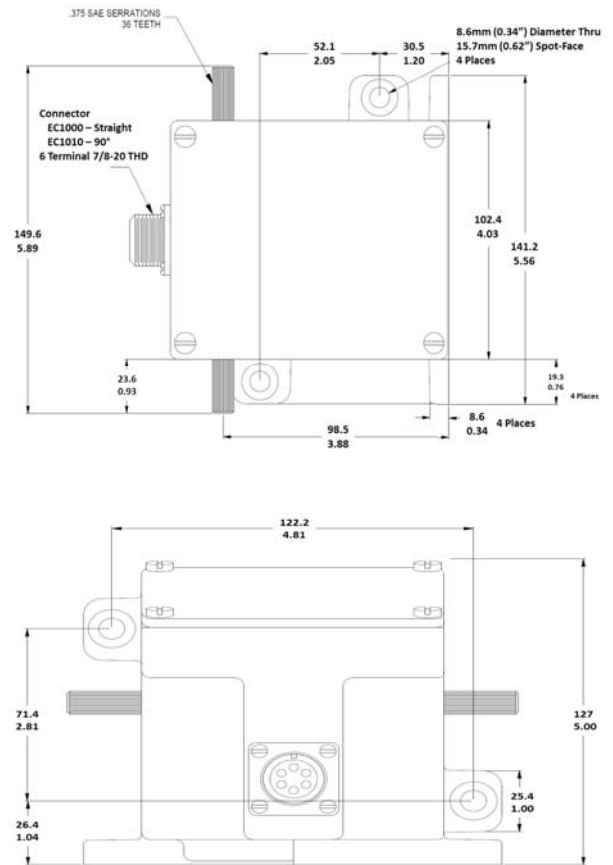

4 INSTALLATION

MOUNTING

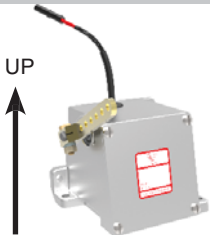

The preferred mounting is with the electrical connector at the top. The actuator must be rigidly mounted as close as possible to the fuel control lever of the engine. Vibration will not affect the operation of the actuator.

LINKAGE

NOTE High quality rod end bearings should be used. Rod end bearings that have high friction can cause instability and require servicing. Levers and linkage should be sturdy yet low in mass for the fastest response.

Arrangement of the linkage for actuation of the engine fuel control is an important application consideration. For proportional actuators to operate with linear control systems, it is important to obtain a linear relationship between actuator stroke and fuel delivery. The linkage configuration for diesel fuel systems is typically as illustrated in Diagram 1. The lever on the actuator should be nearly parallel to the pump lever at the mid fuel position for linear fuel control.

For proportional actuators to operate with non-linear systems, it is important to obtain a non-linear relationship between actuator stroke and fuel delivery. Carbureted, PT Pumps (CUMMINS), or other non-linear fuel systems require a non-linear fuel linkage configuration as illustrated in Diagram 2. A non-linear fuel system results when more engine power is developed for a given stroke at positions of low fuel settings rather than at high fuel settings. In this case the levers should be parallel at full load.

In general, the linkage should be adjusted so that the fuel control lever minimum and maximum fuel stops are used rather than the actuator internal mechanical stops. The actuator should be adjusted so that it operates over at least one half (12 degrees) of its available travel.

DIAGRAM 1 FUEL LEVER AT MID FUEL POSITION

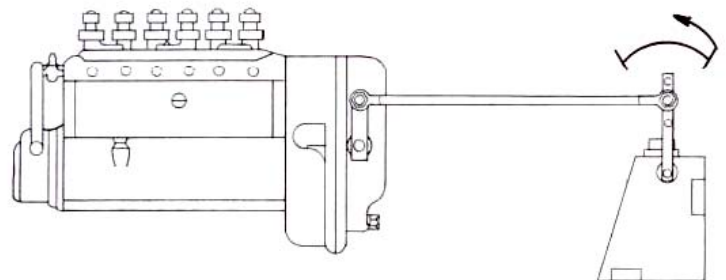
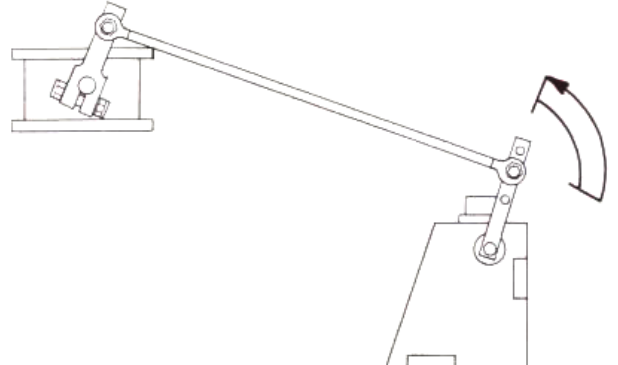

DIAGRAM 2 FUEL LEVER AT FULL FUEL POSITION



5 WIRING

PRODUCT PREFIX	System Voltage		Multi Voltage	Connector	Notes
	12	24			
ACB			▪	Military Style	See below for wiring.
ADB			▪		
ADC	▪	▪		Packard or Commercial	Prewired for 12 or 24 Volt
ADD	▪	▪			

WIRING MULTI VOLTAGE MILITARY STYLE CONNECTOR UNITS

The mating electrical connector must be wired in a configuration dependent on the system voltage supply. The maximum wire size that will fit into the actuator mating half connector is #16 AWG (1.3 mm sq.). GAC's CH1203 is a pre-wired actuator cable harness 12 feet (4 Meters) in length and suitable for use on 12 or 24 volt systems. Other options are available from GAC.

NOTE Larger gauge wire for cables longer than 10 ft. (3 m) will reduce current losses and maintain full rotation of the actuator. Twisted and shielded actuator cable is recommended for EMI concerns.

12 Volt Applications It is preferable to connect four wires, one to each of the coils and wire per **Diagram 3**. Maximum current is 8 Amps. The recommended wire size is at least #16 AWG (1.3 mm sq.).

DIAGRAM 3 12 VOLT OPERATION

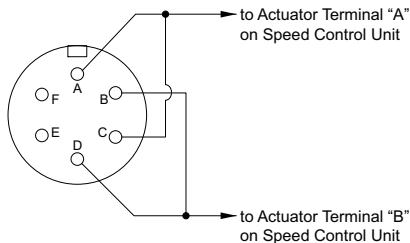

24 Volt Applications A simple jumper wire between pins B and C at the mating half connector can be made. The remaining two pins, A and D, can be extended to the required length. Maximum current is 4 Amps. The recommended wire size is at least #18 AWG (1.0 mm sq.). See **Diagram 4**.

DIAGRAM 4 24 VOLT OPERATION

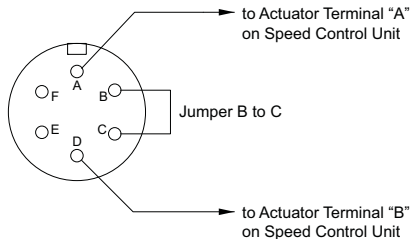

ADB225F This version of the actuator includes a position sensor. See **Diagram 5** for wiring. A GAC speed control unit that includes fuel management electronics is required to interface with this sensor. See the appropriate speed control unit literature for complete wiring information.

DIAGRAM 5 ADB225F WIRING

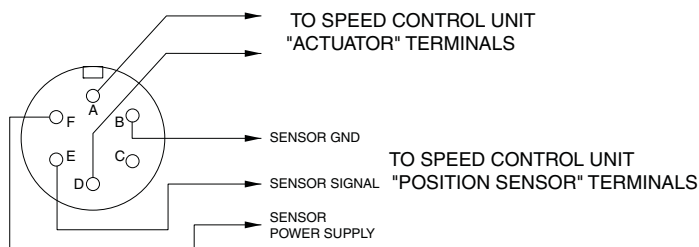

6 ADJUSTMENTS

Reconfirm that the linkage is not binding and that friction is minimal. Before starting the engine, push the actuator to the full fuel position and release. It should return instantly to the no fuel position without any binding. Once the engine has been started, the linkage can be optimized by temporarily inserting an ammeter in one of the wires between the speed control unit and the actuator or by measuring the voltage across the actuator. Measure the actuator current or voltage at no load and full load. The range and the starting current or voltage are important for optimizing the linkage system. Typical values are shown in the table following for 12 volt and 24 volt Systems.

ACTUATOR CURRENT/VOLTAGE RANGE CHART

	12 VOLTS	24 VOLTS
No Load	2.5 Amp, 4 Volts	0.5 Amps, 12 Volts
Full Load	4 Amp, 6 Volts	1.2 Amps, 18 Volts

To increase the range of the actuator voltage or current, move the linkage to a lower hole on the actuator lever. A lower range of actuator current than suggested can cause instability or poor performance.

To increase or decrease the no load current or voltage. Adjust the length of the link between the actuator and the engine fuel control.

NOTE Smaller angles of actuator travel may improve transient performance, but will reduce available force at the fuel control lever. Allowing the actuator to operate through at least one half (12 degrees) of its stroke will usually provide near optimum response.

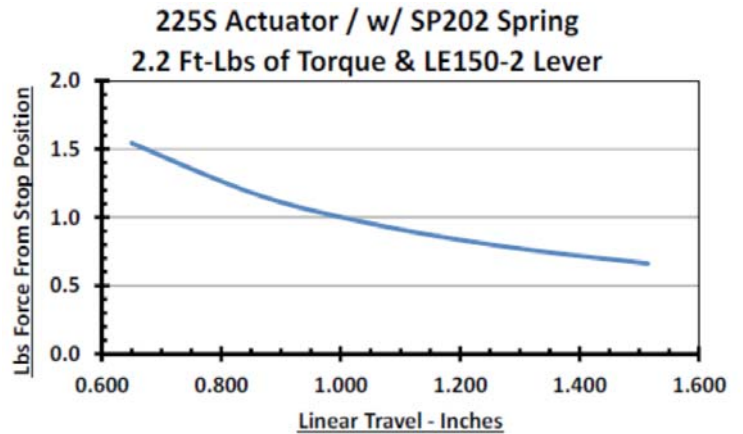

225 Series Actuator Spring Options

Actuator spring rate options offer an additional parameter to adjust for optimum governor stability and response.

ACTUATOR MODEL	SPRING PART NUMBER	SPRING RATE LBS / INCH	NOMINAL PRELOAD - LBS.
ADD225S ADC225S ADB225KS ADB225 ACB225 ADB225F	SP202	9.8	4.0
ADC225GS ADC225GAS ADD225GSC	SP203	4.7	4.6
ADC225JS	SP207	22.0	4.0
ADC225D1S (FIRE PUMP)	SP202 SP152	9.8 3.0	6.0
ADC225HS	SP101	4.6	2.7

If the governor system fails to operate, make the following tests at the actuator mounted connector while moving the actuator through its stroke.

MEASURING THE RESISTANCE

ADB225	
TERMINALS	RESISTANCE
A to B	2.5 Ohms
C to D	2.5 Ohms
A to C	Infinity
A to Housing	Infinity
C to Housing	Infinity

ADC225 & ADD225	
TERMINALS	RESISTANCE
Red to White (12 V)	1.25 Ohms
Red to White (24 V)	5.0 Ohms
Red to Housing	Infinity
White to Housing	Infinity

Energize the actuator to full fuel (follow steps in control unit publication) and manually move the actuator through its range. No binding or sticking should occur. If the actuator passes the tests, the problem is elsewhere in the system. Refer to the control unit troubleshooting publication.

