

ESD5500-II Fusion Series Speed Control Unit

1 SPECIFICATIONS

PERFORMANCE

Isochronous Operation	± 0.25% or better
Speed Range / Governor	1 - 7.5 KHz Continuous
Speed Drift with Temperature	±1% Maximum
Idle Adjust CW	60% of Set Speed
Idle Adjust CCW	Less than 1200 Hz
Droop Range	1 - 5% regulation
Droop Adj. Max. (K-L Jumpered)	400 Hz., ±75 Hz per 1.0 A change
Droop Adj. Min. (K-L Jumpered)	15 Hz., ±75 Hz per 1.0 A change
Speed Trim Range	± 200 Hz
Remote Variable Speed Range	500 - 7.5 KHz
Terminal Sensitivity	
J	100 Hz., ±15 Hz/Volt @ 5.0 K Impedance
L	735 Hz., ±60 Hz/Volt @ 65 K Impedance
N	148 Hz., ±10 Hz/Volt @ 1 Meg Impedance
P	10 VDC Supply @ 20 mA Max

RELIABILITY

Vibration	1G @ 20-100 Hz
Testing	100% Functionally Tested

INPUT / OUTPUT

DC Supply	12-24 VDC Battery Systems Transient and Reverse Voltage Protected
Polarity	Negative Ground (Case Isolated)
Power Consumption	50mA continuous plus actuator current
Speed Signal Range	1.0-50 VAC
Actuator Current @ 77°F (25°C)	8A Max Continuous
Speed Sensor Signal	1.0 - 120 Volts RMS

ENVIRONMENTAL

Ambient Temperature	-40° to 85°C (-40 to 180°F)
Relative Humidity	up to 95%
All Surface Finishes	Fungus-Proof and Corrosion-Resistant

PHYSICAL

Dimension	See Section 2 "Installation"
Weight	1.8 lbs. (820 grams)
Mounting	Any position, Vertical Preferred

COMPLIANCE / STANDARDS

Agency	CE and RoHS Requirements
--------	--------------------------

2 INSTALLATION

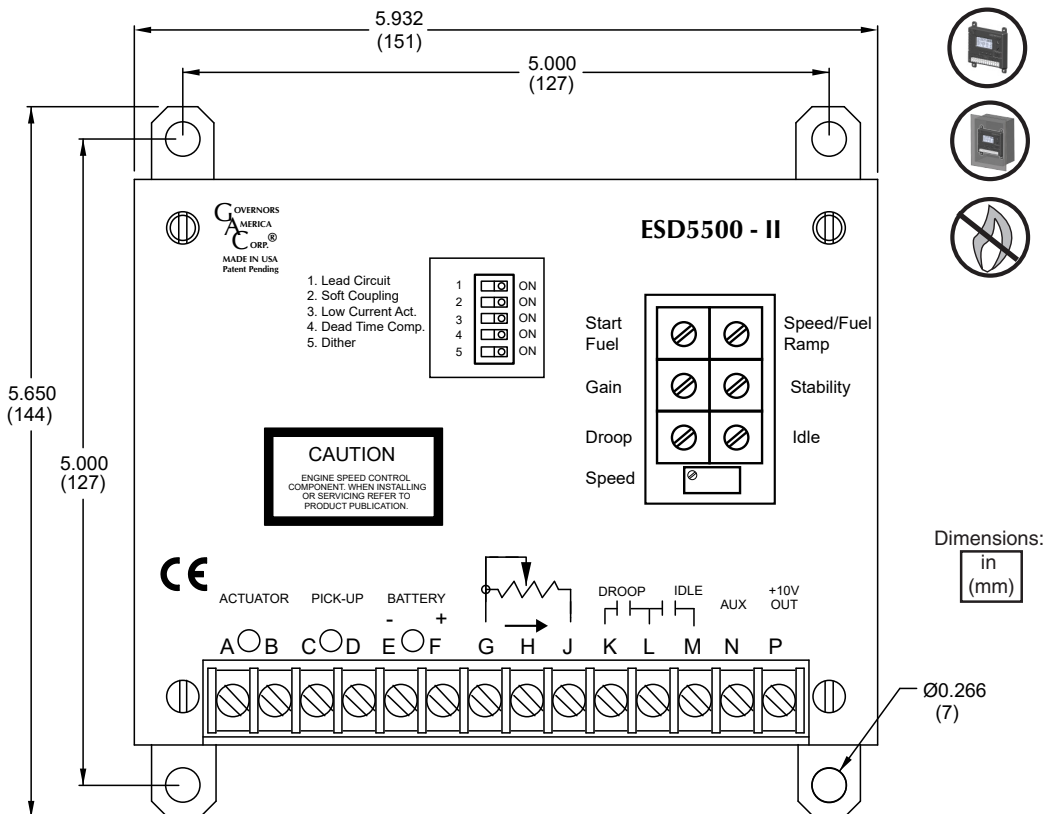

Vertical orientation allows for the draining of fluids in moist environments.



Mount in a cabinet, engine enclosure, or sealed metal box.



Avoid Extreme Heat

Dimensions:

in
(mm)

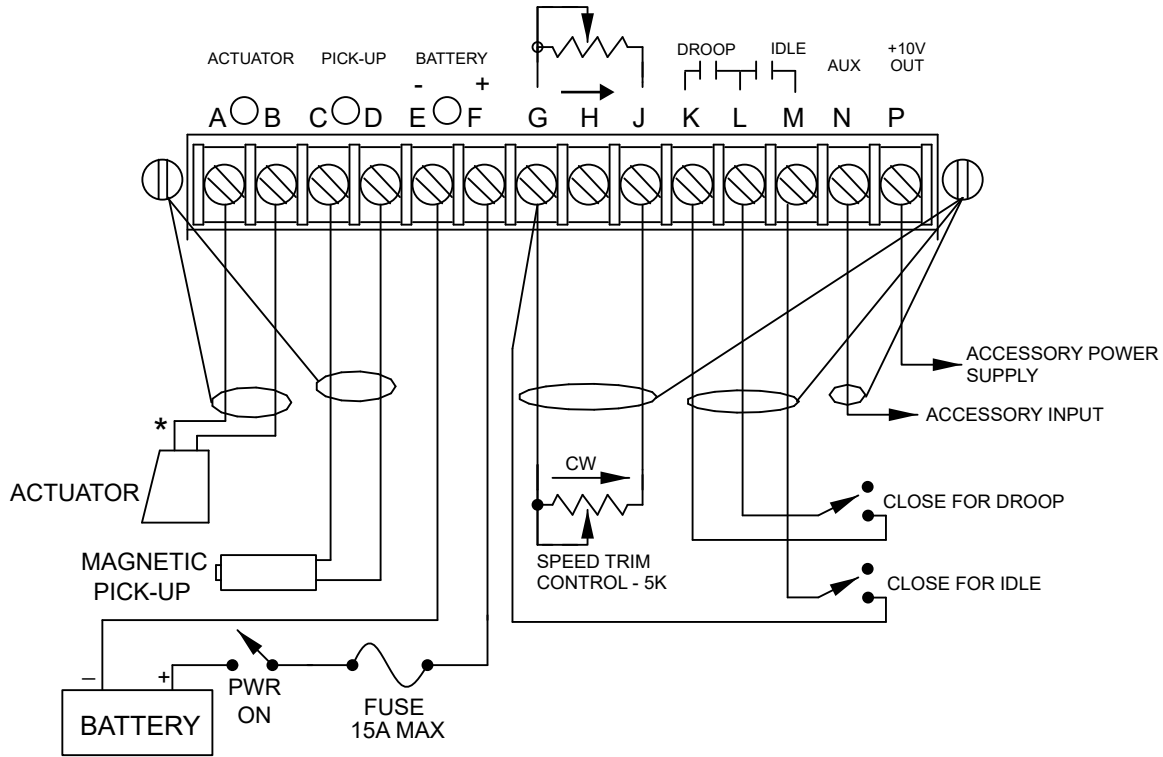

* SEE SPECIFIC ACTUATOR PUBLICATION FOR PROPER WIRING OF ACTUATOR BASED ON BATTERY VOLTAGE

TERMINAL	DEFINITION	NOTES
A & B	ACTUATOR (+/-)	#16 AWG (1.3mm sq) or larger wire
C & D	MAGNETIC SPEED PICKUP (D is ground)	Wires must be twisted and/or shielded for their entire length Gap between speed sensor and gear teeth should not be smaller than 0.02 in. (.51mm) Speed sensor voltage should be at least 1V AC RMS during crank
E & F	BATTERY POWER (-/+)	#16 AWG (1.3mm sq) or larger wire A 15 amp fuse must be installed in the positive battery lead to protect against reverse voltage Battery positive (+) input is Terminal F
G	GROUND SIGNAL	Low current for switches & potentiometers
H	JUMPER INPUT	Add Jumper for 12V Battery or Actuator Currents Above 5A
J	VARIABLE SPEED/TRIM INPUT	0 - 5 kΩ Input
K & L	DROOP SELECT	Active When Closed
M	IDLE SELECT	Close for Idle
N	ACCESSORY INPUT	Load Sharing / Synchronizing Input 0-10V Reverse Polarity
P	ACCESSORY POWER SUPPLY	10 Volt Output, 20 mA Max

NOTE There are 3 LEDs to indicate actuator voltage output, magnetic speed pickup input signal, and battery. The Pick-Up LED will illuminate solid when there is more than 2 VAC going to the terminal.

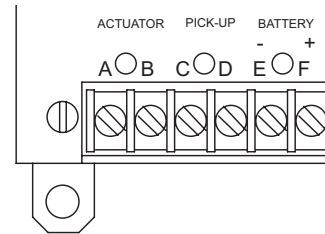

Low Current Act. Low current actuators, also known as, “Light-Force”, is for small actuators like the T1 ATB, ALR/ALN, and the 100/103/104 series actuators. Enable this switch for use with low current actuators.

1. Lead Circuit
2. Soft Coupling
3. Low Current Act.
4. Dead Time Comp.
5. Dither

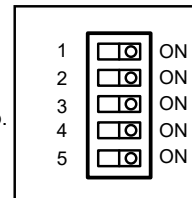

NOTE This must be set prior to startup. Contact GAC if you need to confirm your actuator selection.

RECOMMENDATIONS

1. Shielded cable should be used for all external connections to the ESD control.
2. One end of each shield, including the speed sensor shield, should be grounded to a single point on the ESD case.

4 ADJUSTMENTS BEFORE ENGINE STARTUP

IMPORTANT Make sure the following adjustments are set before starting the engine.

Gain	Middle Position
Stability	Middle Position
Speed	Middle Position
Start Fuel	Full CW (Maximum Fuel)
Speed/Fuel Ramp	Full CCW (Fastest)

5 START THE ENGINE

The speed control unit governed speed setting is factory set at approximately engine idle speed. (1000 Hz., Speed sensor signal or 600 RPM)

Crank the engine with DC power applied to the governor system. The actuator will energize to the maximum fuel position until the engine starts. The governor system should control the engine at a low idle speed.

6 GOVERNOR SPEED SETTING

The governed speed set point is increased by clockwise rotation of the Speed adjustment control. Remote speed adjustment can be obtained with an optional 5K Speed Trim Control.

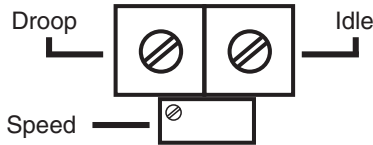

NOTE The Speed potentiometer is a 25 turn potentiometer

7 START FUEL & IDLE ADJUSTMENT

START FUEL ADJUSTMENT

- Place the engine in idle by connecting Terminals M & G and placing the external selector switch in the Idle position.
- Adjust the Idle or operating speed for as low a speed setting as the application allows. (CCW turn to lower speed)
- Adjust the Start Fuel CCW until engine speed begins to fall. Increase the Start Fuel slightly so that the idle speed is returned to the desired level.
- Stop the engine.

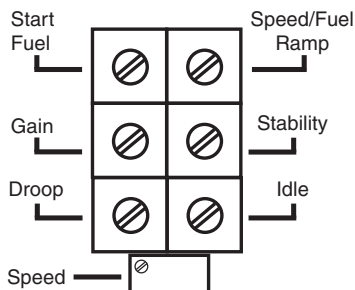

Idle Speed Setting The Idle setting must be set to the desired speed. If the Idle speed setting was not adjusted as detailed above in "Start Fuel Adjustment", then place the optional external selector switch in the Idle position. The idle speed set point is increased by the clockwise rotation of the Idle adjustment control. When the engine is at idle speed, the speed control unit applies droop to the governor system to insure stable operation.

8 OPERATION

One of two methods of operation for the ESD5500-II may be now selected.

METHOD 1 Start the engine and accelerate directly to the operating speed (Generator Sets, etc.).

Procedure	
1.	Remove the connection between Terminals M & G.
2.	Start the engine and adjust the Speed/Fuel Ramp for the least smoke during acceleration to rated speed and to prevent overshoot
3.	If the starting smoke is excessive, adjust the Start Fuel slightly CCW.
4.	If the starting time is too long, adjust the Start Fuel slightly CW.

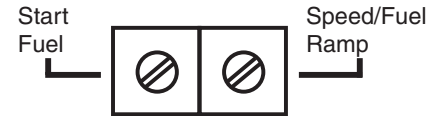

METHOD 2 Start the engine and maintain at an idle speed for a period of time prior to accelerating to the operating speed. This method separates the starting process so that each may be optimized for the lowest smoke emissions.

Procedure	
1.	Replace the connection between Terminals M & G with a switch, usually an oil pressure switch or toggle switch.
2.	Start the engine.
3.	If the starting smoke is excessive, the Start Fuel may need to be adjusted slightly CCW.
4.	If the starting time is too long, the Starting Fuel may need to be adjusted slightly CW.
5.	When the switch opens, adjust the Speed Ramping for the least amount of smoke when accelerating from idle speed to rated speed or to prevent overshoot.

NOTE The idle speed must be set below operation speed.

9 ADJUSTING FOR STABILITY

Once the engine is running at operating speed and at no load, the following governor performance adjustments can be made to increase engine stability.

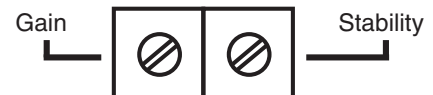

STABILITY ADJUSTMENT

PARAMETER	PROCEDURE
A. Gain	<ol style="list-style-type: none"> Rotate the Gain adjustment clockwise until instability develops. Then, gradually move the adjustment counterclockwise until stability returns. Finally, move the adjustment one division further counterclockwise to insure stable performance (270° potentiometer). If instability persists, adjust the next parameter.
B. Stability	<ol style="list-style-type: none"> Follow the same adjustment procedure, steps 1 - 3, as the Gain parameter.

NOTE Normally, adjustments made at no load achieve satisfactory performance. If further performance improvements are required, refer to Section (11) SYSTEM TROUBLESHOOTING.

10 ADDITIONAL FEATURES & OPTIONAL WIRING

Speed Droop Operation Droop is typically used for the paralleling of engine driven generators. When in droop operation, the engine speed will decrease as engine load increases. The percentage of droop is based on the actuator current change from no engine load to full load.

1. Place the optional external selector switch in the Droop position. Droop is increased by clockwise rotation of the Droop adjustment control.
2. After the droop level has been adjusted, the rated engine speed setting may need to be reset. Check the engines speed and adjust that speed setting accordingly.

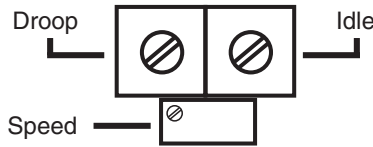

NOTE Though a wide range of droop is available with the internal control, droop level requirements of 10% are unusual. If droop levels experienced are higher or lower than those required, contact GAC for assistance. Droop is based on a speed sensor frequency of 4000 Hz. and an actuator current change of 1 amp from no load to full load. Applications with higher speed sensor signals will experience less percentage of droop. Applications with more actuator current change will experience higher percentages of droop. Protected against reverse voltage by a series diode. A 15 amp fuse must be installed in the positive battery lead. Protected against short circuit to actuator (shuts off current to actuator), unit automatically turns back on when short is removed.

Dither Certain applications require a dither function to reduce sticking actuators in contaminated environments or increase stability. This switch can be used to add a small dither/frequency to the actuator output to prevent these occurrences.

Accessory Input The AUX Terminal N accepts input signals from load sharing units, auto synchronizers, and other governor system accessories, GAC accessories are directly connected to this terminal.

- NOTE**
1. Terminal N is sensitive. Accessory connections must be shielded.
 2. When an accessory is connected to Terminal N, the speed will decrease and the speed adjustment must be reset.
 3. When operating in the upper end of the control unit frequency range, a jumper wire or frequency trim control may be required between Terminals G and J. This increases the frequency range of the speed control to over 7000 Hz (4200 RPM).
 4. If the auto synchronizer is used alone, not in conjunction with a load sharing module, a 3 ohm resistor should be connected between Terminals N and P. This is required to match the voltage levels between the speed control unit and the synchronizer.

Accessory Supply The +10 volt regulated supply, Terminal P, can be utilized to provide power to GAC governor system accessories. Up to 20 mA of current can be drawn from this supply. Ground reference is Terminal G.

CAUTION A short circuit on this terminal can damage the speed control unit. Never jumper Terminal P directly to Terminal N.

Wide Range Remote Variable Speed Operation A single remote speed adjustment potentiometer can be used to adjust the engine speed continuously over a specific speed range.

Select the desired speed range and corresponding potentiometer value. (Refer to TABLE 1 below) If the exact range cannot be found, select the next higher range potentiometer.

NOTE An additional fixed resistor may be placed across the potentiometer to obtain the exact desired range. Connect the speed range potentiometer as shown in Section 12 using Terminals G and J.

To maintain engine stability at the minimum speed setting, a small amount of droop can be added using the DROOP adjustment. At the maximum speed setting the governor performance will be near isochronous, regardless of the droop adjustment setting.

NOTE Contact GAC for assistance if difficulty is experienced in obtaining the desired variable speed governing performance.

TABLE 1

SPEED RANGE		POTENTIOMETER VALUE
900 Hz	540 RPM	1 K
2400 Hz	1440 RPM	5 K
3000 Hz	1800 RPM	10 K
3500 Hz	2100 RPM	25 K
3700 Hz	2220 RPM	50 K

NOTE RPM values shown are for 100 teeth flywheel

$$\text{MPU Signal (Hz)} = \frac{\text{RPM} \times \text{Flywheel Teeth}}{60 \text{ sec}}$$

POTENTIOMETER WIRING

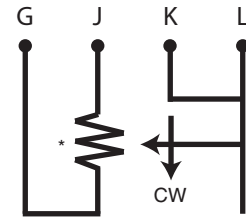

* Select proper potentiometer value from Table 1

SYSTEM INOPERATIVE

If the engine governing system does not function, the fault may be determined by performing the voltage tests described in Steps 1 through 4. Positive (+) and negative (-) refer to meter polarity. Should normal values be indicated during troubleshooting steps, and then the fault may be with the actuator or the wiring to the actuator. Tests are performed with battery power on and the engine off, except where noted. See actuator publication for testing procedure on the actuator.

STEP	WIRES	NORMAL READING	PROBABLE CAUSE OF ABNORMAL READING
1	F(+) & E(-)	Battery Supply Voltage (12 or 24 VDC)	<ol style="list-style-type: none"> DC battery power not connected. Check for blown fuse, switch off power. Low battery voltage Wiring error
2	C(+) & D(-)	1.0 VAC RMS min. while cranking	<ol style="list-style-type: none"> Gap between speed sensor and gear teeth too great. Check Gap. Improper or defective wiring to the speed sensor. Resistance between D and C should be 160 to 1200 ohms. See specific mag pickup data for resistance. Defective speed sensor.
3	P(+) & G(-)	10 VDC, Internal Supply	<ol style="list-style-type: none"> Short on Terminal P. Defective speed control unit.
4	F(+) & A(-)	1.0 - 2.0 VDC while cranking	<ol style="list-style-type: none"> Speed parameter set too low Short/open in actuator wiring Defective speed control Defective actuator, see Actuator Troubleshooting

INSTABILITY

INSTABILITY	SYMPTOM	PROBABLE CAUSE OF ABNORMAL READING
Fast Periodic	The engine seems to jitter with a 3Hz or faster irregularity of speed.	<ol style="list-style-type: none"> Make sure switch #1 Lead Circuit is set to "OFF". Readjust the Gain and Stability for optimum control. Turn off other electrical equipment that may be causing interference. Turn switch #5 Dither on/off.
		<ol style="list-style-type: none"> Readjust the Gain and Stability Adjust the Dead Time Comp by setting switch #4 to "ON". Check fuel system linkage during engine operation for: <ol style="list-style-type: none"> binding high friction poor linkage Turn switch #5 Dither on/off.
Slow Periodic	An irregularity of speed below 3Hz.	<ol style="list-style-type: none"> Increasing the Gain should reduce the instability but not totally correct it. If this is the case, there is most likely a problem with the engine itself. Check for: <ol style="list-style-type: none"> engine mis-firings an erratic fuel system load changes on the generator set voltage regulator. If throttle is slightly erratic, but performance is fast, then move switch #1 Lead Circuit to the "OFF" position. Turn switch #5 Dither on/off.
Non-Periodic	Erratic Engine Behavior	<ol style="list-style-type: none"> Increasing the Gain should reduce the instability but not totally correct it. If this is the case, there is most likely a problem with the engine itself. Check for: <ol style="list-style-type: none"> engine mis-firings an erratic fuel system load changes on the generator set voltage regulator. If throttle is slightly erratic, but performance is fast, then move switch #1 Lead Circuit to the "OFF" position. Turn switch #5 Dither on/off.

If unsuccessful in solving instability, contact GAC for assistance.
 GAC@governors-america.com or call: 1-413-233-1888

UNSATISFACTORY PERFORMANCE

SYMPTOM	NORMAL READING	PROBABLE CAUSE OF ABNORMAL READING
Engine Overspeeds	1. Do Not Crank. Apply DC power to the governor system.	1. After the actuator goes to full fuel, disconnect the speed sensor at Terminal C & D. If the actuator is still at full fuel-speed then the speed control unit is defective. 2. If the actuator is at minimum fuel position and there exists an erroneous position signal, then check speed sensor cable.
	2. Manually hold the engine at the desired running speed. Measure the DC voltage between Terminals A(-) & F(+) on the speed control unit.	1. If the voltage reading is 1.0 to 1.5 VDC: a. Speed adjustment is set above desired speed b. Defective speed control unit 2. If voltage reading is above 1.5 VDC then check for: a. actuator binding b. linkage binding 3. If the voltage reading is below 0.8 VDC: a. Defective speed control unit
Actuator does not energize fully	1. Measure the voltage at the battery while cranking.	1. If the voltage is less than: a. 7V for a 12V system, or b. 14V for a 24V system, Then: Check or replace battery.
	2. Momentarily connect Terminals A and F. The actuator should move to the full fuel position.	1. Actuator or battery wiring in error 2. Actuator or linkage binding 3. Defective actuator
Engine remains below desired governed speed	1. Measure the actuator output, Terminals A & B, while running under governor control.	1. If voltage measurement is within 2 VDC of the battery supply voltage level, then fuel control is restricted from reaching full fuel position, possibly due to mechanical governor, carburetor spring, or linkage interference. 2. Speed parameter set too low

Insufficient Magnetic Speed Signal

A strong magnetic speed sensor signal will eliminate the possibility of missed or extra pulses. The speed control unit will govern well with 1.0 volts RMS speed sensor signal. A speed sensor signal of 3 VAC or greater at governed speed is recommended. Measurement of the signal is made at Terminals C and D.

The amplitude of the speed sensor signal can be raised by reducing the gap between the speed sensor tip and the engine ring gear. The gap should not be any smaller than 0.020 in (0.45 mm). When the engine is stopped, back the speed sensor out by 3/4 turn after touching the ring gear tooth to achieve a satisfactory air gap.



720 Silver Street,
Agawam, MA 01001 USA
info@governors-america.com
www.governors-america.com